

## TEMPLATE

RIM TYPE EXIT DEVICES HOLE LOCATIONS, SIZE AND TYPE INDICATED ON TEMPLATE.

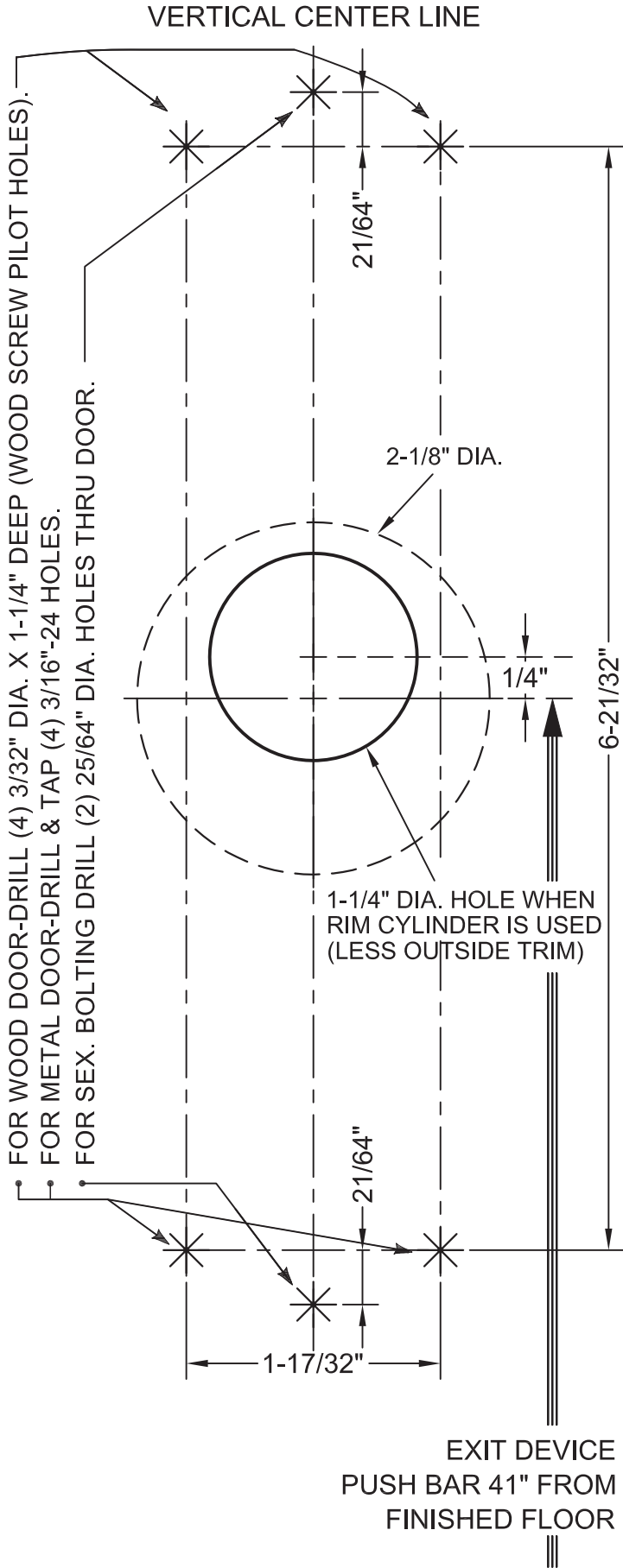

## TEMPLATE

RIM TYPE FIRE EXIT DEVICES TRIM HOLE LOCATIONS.

